



Pump/Motor Mounts

Leading the Industry in Quality, Service and Availability



INDEX:

| | |
|--|----|
| Magnaloy General Information | 2 |
| Flexible Drive Couplings..... | 2 |
| SAE & Metric Mount | |
| Dimensions..... | 3 |
| NEMA 'C' Motor Dimensions..... | 4 |
| Cast Aluminum Mounts | 4 |
| Horizontal Pump/Motor Mounts | 4 |
| Mount Selection Method..... | 5 |
| Horizontal Pump/Motor Mount Selection Tables..... | 5 |
| Vertical Pump/Motor Mounts | 8 |
| Mount Selection Method..... | 8 |
| Vertical Pump/Motor Mount Selection Tables..... | 9 |
| Pump/Engine Mounts | 11 |
| Mount Selection Method..... | 11 |
| Pump/Engine Mount Selection Tables..... | 11 |
| Welded Steel Mounts | 14 |
| Horizontal Welded Steel Pump/Motor Mounts | 14 |
| Horizontal Pump/Motor Mount Selection Tables..... | 14 |
| Vertical Welded Steel Pump/Motor Mounts | 16 |
| Vertical Pump/Motor Mount Selection Tables..... | 16 |
| Weld Steel Pump/Engine Mounts | 18 |
| Pump/Engine Mount Selection Tables..... | 18 |
| Other Magnaloy Products | 20 |

magnaloy coupling company

P.O. Box 455 Alpena, MI 49707

989-356-2186

A Division of Douville Johnston Corporation

Fax: 989-354-4190

<http://www.magnaloy.com>

Power Unit design is greatly simplified by use of the Magnaloy Pump Mount. Direct mounting of flange-mount pumps to NEMA C'face motors or Pilot mount engines via a Magnaloy Mount assures accurate shaft alignment and eliminates the need for a coupling guard, foot brackets, shims, risers and mount plate. The result is the easiest to install, most accurate and cost effective method available to mount a pump to a drive unit.

For over 30 years Magnaloy has produced the highest quality flexible drive couplings in the industry. Magnaloy's long tradition of high quality and immediate delivery has become an industry goal for other manufacturers to attain. Every mount Magnaloy manufactures is guaranteed to be within .003 inch concentric from the motor pilot to pump pilot. Further, the mounting faces are parallel to each other and perpendicular to the pilot centerline within .002 inch. These exacting tolerances mean accurate shaft alignment which helps prolong bearing, seal and coupling life in addition to reducing noise and vibration. Other mount manufacturers talk about quality, but Magnaloy puts it in writing with measurable standards (See Illustration A)

Magnaloy is the most complete, single source for Horizontal, Vertical and Engine requirements. A large selection of SAE and Metric pump mounting flanges to NEMA motors and I.C. Engines in a variety of lengths are available from stock for immediate shipment. OR special requirements can be met from our complete offering of Welded Steel Mounts. Whatever your mounting needs, you need look no further than Magnaloy.

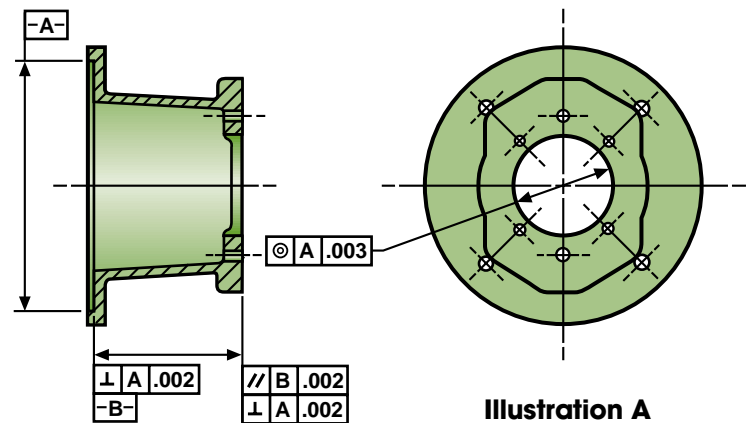
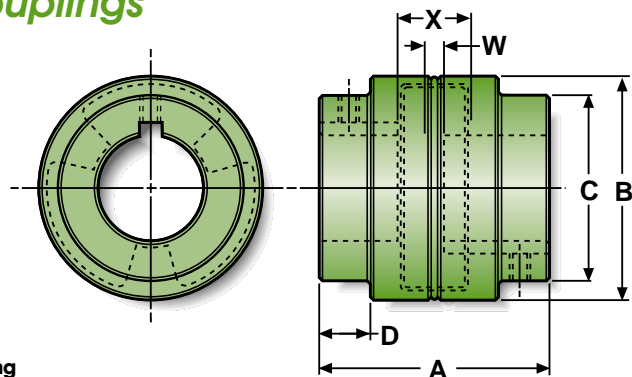

TABLE 1 - Magnaloy Flexible Drive Couplings

The following basic Rating & Dimensional data is provided for general selection assistance. Complete selection specifications for standard and semi-standard bores, spline bores, clamp and steel bushing options and installation instructions are included in the Magnaloy Coupling Catalog - available upon request.



| Coupling Model | Maximum Bore (inches) | HP Rating Per 100 RPM (STD insert) | HP Rating Per 100 RPM (Urethane insert) | HP Rating Per 100 RPM (Hyrel insert) | A | B | C | D | W(Min) | X(Max) |
|----------------|-----------------------|------------------------------------|---|--------------------------------------|------|------|------|------|--------|--------|
| | | | | | | | | | | |
| 100 | 1 1/8 | .55 | .82 | 1.65 | 2.54 | 2.60 | 2.00 | .56 | 1/16 | .90 |
| 200 | 1 3/8 | .64 | .96 | 1.92 | 3.10 | 2.90 | 2.25 | .68 | 1/16 | .90 |
| 300 | 1 5/8 | 1.12 | 1.68 | 3.36 | 3.58 | 3.45 | 2.90 | .78 | 1/16 | .98 |
| 400 | 1 7/8 | 1.69 | 2.50 | 5.10 | 4.24 | 3.98 | 3.05 | 1.00 | 1/16 | 1.20 |
| 500 | 2 3/8 | 3.50 | 5.30 | 10.50 | 4.67 | 4.80 | 4.00 | 1.04 | 1/16 | 1.41 |
| 600 | 2 5/8 | 7.90 | 11.90 | 23.70 | 5.98 | 5.98 | 4.50 | 1.60 | 1/16 | 1.36 |
| 700 | 2 7/8 | 18.60 | 27.90 | 46.50 | 6.99 | 6.90 | 5.19 | 2.08 | 1/16 | 1.97 |

TABLE 2 - SAE - 2 Bolt Mount

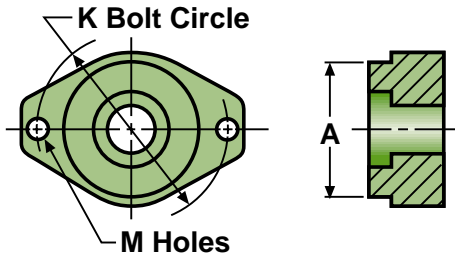

| | A | K | M |
|---------------|-------|--------|-------|
| SAE AA | 2.000 | 3.250 | 0.406 |
| SAE A | 3.250 | 4.187 | 0.438 |
| SAE B | 4.000 | 5.750 | 0.562 |
| SAE C | 5.000 | 7.125 | 0.688 |
| SAE D | 6.000 | 9.000 | 0.812 |
| SAE E | 6.500 | 12.500 | 1.062 |
| SAE F | 7.000 | 13.781 | 1.062 |

Mounting Flange Pilot Dim. Flange Dimensions

TABLE 3 - SAE - 4 Bolt Mount

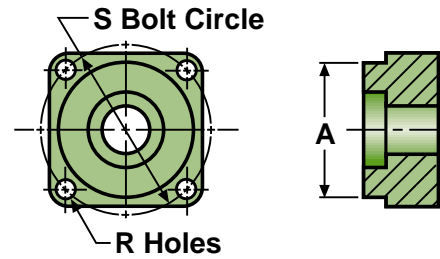

| | A | S | R |
|----------------|-------|--------|-------|
| USA4F17 | 1.781 | 2.838 | 0.375 |
| SAE A | 3.250 | 4.125 | 0.438 |
| SAE B | 4.000 | 5.000 | 0.562 |
| SAE C | 5.000 | 6.375 | 0.562 |
| SAE D | 6.000 | 9.000 | 0.812 |
| SAE E | 6.500 | 12.500 | 0.812 |
| SAE F | 7.000 | 13.781 | 1.062 |

Mounting Flange Pilot Dim. Flange Dimensions

TABLE 4 - Metric Oval Mount (2 Bolt)

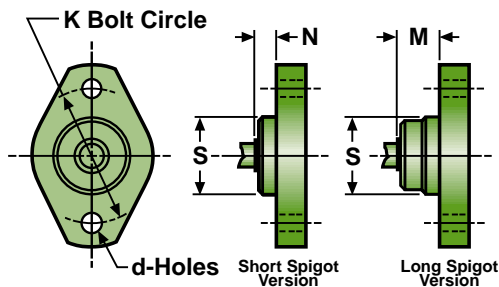

(All dimensions in mm)

| | S | K | d | N | M |
|---------------|-----|-----|-----|----|----|
| 32 A2 | 32 | 56 | 6.6 | 8 | 16 |
| 40 A2 | 40 | 63 | 6.6 | 8 | 16 |
| 50 A2 | 50 | 80 | 9 | 8 | 20 |
| 63 A2 | 63 | 100 | 9 | 8 | 20 |
| 80 A2 | 80 | 109 | 11 | 8 | 20 |
| 100 A2 | 100 | 140 | 14 | 10 | 25 |
| 112 A2 | 112 | 160 | 14 | 10 | 25 |
| 125 A2 | 125 | 180 | 18 | 10 | 32 |
| 140 A2 | 140 | 200 | 18 | 10 | 32 |
| 160 A2 | 160 | 224 | 22 | 10 | 40 |
| 180 A2 | 180 | 250 | 22 | 10 | 40 |
| 200 A2 | 200 | 280 | 26 | 10 | 50 |

Mounting Flange Pilot Dim. Flange Dimensions

TABLE 5 - Metric Square Mount (4 Bolt)

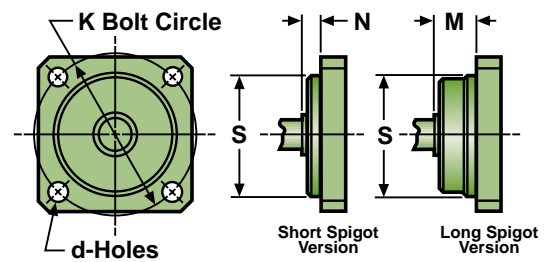

(All dimensions in mm)

| | S | K | d | N | M |
|---------------|-----|-----|----|----|----|
| 63 B4 | 63 | 85 | 9 | 8 | 20 |
| 80 B4 | 80 | 103 | 9 | 8 | 20 |
| 80 S4 | 80 | 100 | 9 | 8 | 20 |
| 100 B4 | 100 | 125 | 11 | 10 | 25 |
| 112 B4 | 112 | 140 | 11 | 10 | 25 |
| 125 B4 | 125 | 160 | 14 | 10 | 32 |
| 140 B4 | 140 | 180 | 14 | 10 | 32 |
| 160 B4 | 160 | 200 | 18 | 10 | 40 |
| 180 B4 | 180 | 224 | 18 | 10 | 40 |
| 200 B4 | 200 | 250 | 22 | 10 | 50 |
| 224 B4 | 224 | 280 | 22 | 10 | 50 |
| 250 B4 | 250 | 315 | 26 | 10 | 50 |

Mounting Flange Pilot Dim. Flange Dimensions

TABLE 6 - NEMA 'C' Motor Dimensions

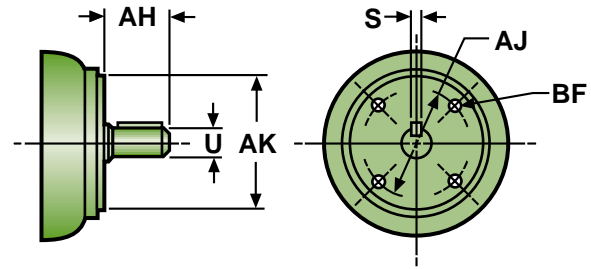

U-Frame Dimensions

| | 182UC 184UC | 213UC 215UC | 254UC 256UC | 284UC 286UC | 324USC 326USC | 324UC 326UC | 364USC 365USC | 364UC 365UC | 404USC 405USC | 404UC 405UC | 444USC 445USC | 444UC 445UC |
|------------|----------------|----------------|----------------|----------------|------------------|----------------|------------------|----------------|------------------|----------------|------------------|----------------|
| AH | 2.125 | 2.75 | 3.50 | 4.625 | 3.00 | 5.375 | 3.50 | 6.125 | 4.00 | 6.875 | 4.00 | 8.375 |
| U | 7/8 | 1 1/8 | 1 3/8 | 1 5/8 | 1 5/8 | 1 7/8 | 1 7/8 | 2 1/8 | 2 1/8 | 2 3/8 | 2 1/8 | 2 7/8 |
| S | 3/16 | 1/4 | 5/16 | 3/8 | 3/8 | 1/2 | 1/2 | 1/2 | 1/2 | 5/8 | 1/2 | 3/4 |
| AK | 4.50 | 8.50 | 8.50 | 10.50 | 12.50 | 12.50 | 12.50 | 12.50 | 12.50 | 12.50 | 16.00 | 16.00 |
| AJ | 5.875 | 7.25 | 7.25 | 9.00 | 11.00 | 11.00 | 11.00 | 11.00 | 11.00 | 11.00 | 14.00 | 14.00 |
| BF | 3/8-16 | 1/2-13 | 1/2-13 | 1/2-13 | 5/8-11 | 5/8-11 | 5/8-11 | 5/8-11 | 5/8-11 | 5/8-11 | 5/8-11 | 5/8-11 |
| HP* | 1/2 | 3/5 | 7.5/10 | 15/20 | 25/30 | 25/30 | 40/50 | 40/50 | 60/75 | 60/75 | 125/150 | 125/150 |

T-Frame Dimensions

| | 056C | 143TC 145TC | 182TC 184TC | 213TC 215TC | 254TC 256TC | 284TSC 286TSC | 284TC 286TC | 324TSC 326TSC | 324TC 326TC | 364TSC 365TSC | 364TC 365TC | 404TSC 405TSC | 404TC 405TC | 444TSC 449TSC | 444TC 449TC |
|------------|--------|----------------|----------------|----------------|----------------|------------------|----------------|------------------|----------------|------------------|----------------|------------------|----------------|------------------|----------------|
| AH | 2.062 | 2.125 | 2.625 | 3.125 | 3.75 | 3.00 | 4.375 | 3.50 | 5.00 | 3.50 | 5.62 | 4.00 | 7.00 | 4.50 | 8.25 |
| U | 5/8 | 7/8 | 1 1/8 | 1 3/8 | 1 5/8 | 1 5/8 | 1 7/8 | 1 7/8 | 2 1/8 | 1 7/8 | 2 3/8 | 2 1/8 | 2 7/8 | 2 3/8 | 3 3/8 |
| S | 3/16 | 3/16 | 1/4 | 5/16 | 3/8 | 3/8 | 1/2 | 1/2 | 1/2 | 1/2 | 5/8 | 1/2 | 3/4 | 5/8 | 7/8 |
| AK | 4.50 | 4.50 | 8.50 | 8.50 | 8.50 | 10.50 | 10.50 | 12.50 | 12.50 | 12.50 | 12.50 | 12.50 | 12.50 | 16.00 | 16.00 |
| AJ | 5.875 | 5.875 | 7.25 | 7.25 | 7.25 | 9.00 | 9.00 | 11.00 | 11.00 | 11.00 | 11.00 | 11.00 | 11.00 | 14.00 | 14.00 |
| BF | 3/8-16 | 3/8-16 | 1/2-13 | 1/2-13 | 1/2-13 | 1/2-13 | 1/2-13 | 5/8-11 | 5/8-11 | 5/8-11 | 5/8-11 | 5/8-11 | 5/8-11 | 5/8-11 | 5/8-11 |
| HP* | 1/4 | 1/2 | 3/5 | 7.5/10 | 15/20 | 25/30 | 25/30 | 40/50 | 40/50 | 60/75 | 60/75 | 100/125 | 100/125 | 150/200 | 150/200 |

* Horse Power at 1750 RPM

Magnaloy Cast Aluminum Mounts

MAGNALOY CAST ALUMINUM MOUNTS are permanent mold cast of lightweight, high strength aluminum alloy and incorporate many unique design features. Custom molded OSHA orange coupling access covers are included for mounts larger than motor group size 056. These covers are quickly and securely retained via a lip-tab on one end and a single self-tapping screw on the other. Magnaloy's horizontal mounts are supplied with a pre-cast drain hole for residual fluids. This unique feature aids in quick detection of leaky seals and other trouble areas.

Using Magnaloy's Mount ensures a lightweight, high strength, precision mount for efficient assembly, quiet operation, accurate shaft alignment and complete coupling concealment.

Magnaloy Horizontal Pump/Motor Mounts

MAGNALOY'S HORIZONTAL PUMP/MOTOR MOUNTS are available for mounting NEMA C'face motors in frame sizes 56C through 449TSC to most SAE and Metric 2 and 4 bolt pump flanges.

A MOUNT KIT is included which contains all bolts and washers required to attach the pump and motor to the mount.

Horizontal Mount Selection Method

1. Check TABLES 2 thru 5 to determine pump flange size.
2. Measure the pump shaft length from the shaft end to the flange mounting face and ADD to the motor shaft length shown in TABLE 6. An additional 1/16 inch (minimum) is recommended for shaft end clearance.
3. Refer to the appropriate TABLE (7 thru 11) according to the NEMA motor frame size and locate the applicable pump flange selection from STEP 1, above.
4. Select the mount length option (dimension 'XM' or 'M' in tables) based on the minimum length determined in STEP 2, above.
5. Check for proper clearance between the mount inner surfaces and the coupling O.D. (dimension 'Z' and 'CL' in tables). Dimensional data for Magnaloy Couplings is shown in TABLE 1 for reference. A complete Magnaloy Coupling catalog is available upon request.

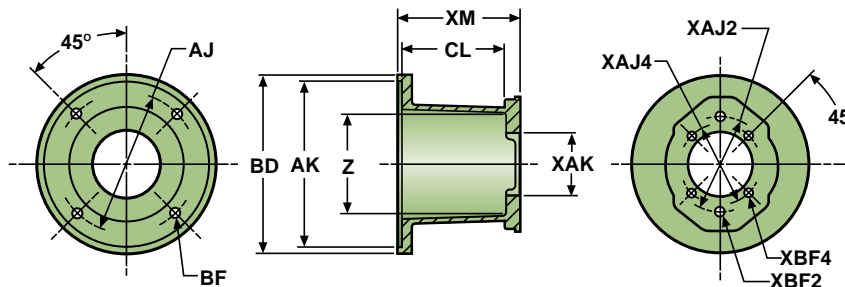

TABLE 7 - NEMA Frames 56C, 143TC/145TC, 182UC/184UC

Horizontal Mounting (or Vertical Mounting - Option A)

| MOTOR END DATA | | PUMP END DATA | | | | | MOUNT NO. | | CL XM | | MOUNT NO. | | CL XM | | MOUNT NO. | | CL XM | |
|----------------|-----------|---------------|-------|--------|-------|---------|-----------|------|-------------------|------|-----------|-------------------|-------|------|-------------------|------|-------|--|
| AJ | BF | BD | AK | XAK | XAJ2 | XBF2 | XAJ4 | XBF4 | CL | XM | CL | XM | CL | XM | CL | XM | | |
| 5.88 | 7/16 | 6.81 | 4.501 | | | | | | | | | | | | | | | |
| USA4F17 | 4 Bolt | 1.782 | | | 2.84 | 5/16-18 | | | M056354F | 2.81 | 3.50 | M056424F | 3.56 | 4.25 | M056454F | 3.81 | 4.50 | |
| SAE AA | 2 Bolt | 2.001 | 3.25 | 3/8-16 | | | | | M056352AA | 2.81 | 3.50 | M056422AA | 3.56 | 4.25 | M056452AA | 3.81 | 4.50 | |
| SAE A | 2(4) Bolt | 3.251 | 4.19 | 3/8-16 | 4.12 | 3/8-16 | | | M056352A | 2.81 | 3.50 | M056422A | 3.56 | 4.25 | M056452A | 3.81 | 4.50 | |
| 80 A2/B4 | 2(4) Bolt | 80.01mm | 109mm | 3/8-16 | 103mm | 5/16-18 | | | M0563580M | 2.81 | 3.50 | M0564280M | 3.56 | 4.25 | M0564580M | 3.81 | 4.50 | |
| 80 S4 | 4 Bolt | 80.01mm | | | 100mm | 5/16-18 | | | M0563580MS | 2.81 | 3.50 | M0564280MS | 3.56 | 4.25 | M0564580MS | 3.81 | 4.50 | |

RADIAL CLEARANCE "Z" = 4.15

MOTOR END DATA

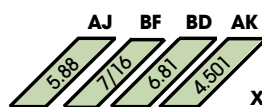

RADIAL CLEARANCE "Z" = 4.15

*RADIAL CLEARANCE "Z" = 4.10

| MOTOR END DATA | | PUMP END DATA | | | | | MOUNT NO. | | CL XM | | MOUNT NO. | | CL XM | |
|----------------|-----------|---------------|-------|--------|-------|---------|-----------|------|--------------------|------|-----------|--------------------|-------|------|
| AJ | BF | BD | AK | XAK | XAJ2 | XBF2 | XAJ4 | XBF4 | CL | XM | CL | XM | CL | XM |
| 5.88 | 7/16 | 6.81 | 4.501 | | | | | | | | | | | |
| USA4F17 | 4 Bolt | 1.782 | | | 2.84 | 5/16-18 | | | M056504F | 4.31 | 5.00 | M056524F | 4.56 | 5.25 |
| SAE AA | 2 Bolt | 2.001 | 3.25 | 3/8-16 | | | | | M056502AA | 4.31 | 5.00 | M056522AA | 4.56 | 5.25 |
| SAE A | 2(4) Bolt | 3.251 | 4.19 | 3/8-16 | 4.12 | 3/8-16 | | | M056502A | 4.31 | 5.00 | M056522A | 4.56 | 5.25 |
| SAE B | 2(4) Bolt | 4.001 | 5.75 | 1/2-13 | 5.00 | 1/2-13 | | | M056502B* | 3.93 | 5.00 | M056522B* | 4.18 | 5.25 |
| 80 A2/B4 | 2(4) Bolt | 80.01mm | 109mm | 3/8-16 | 103mm | 5/16-18 | | | M0565080M | 4.31 | 5.00 | M0565280M | 4.56 | 5.25 |
| 80 S4 | 4 Bolt | 80.01mm | | | 100mm | 5/16-18 | | | M0565080MS | 4.31 | 5.00 | M0565280MS | 4.56 | 5.25 |
| 100 A2/B4 | 2(4) Bolt | 100.01mm | 140mm | 1/2-13 | 125mm | 3/8-16 | | | M05650100M* | 3.93 | 5.00 | M05652100M* | 4.18 | 5.25 |

PUMP FLANGE

PUMP END DATA

5.00 LENGTH

5.25 LENGTH

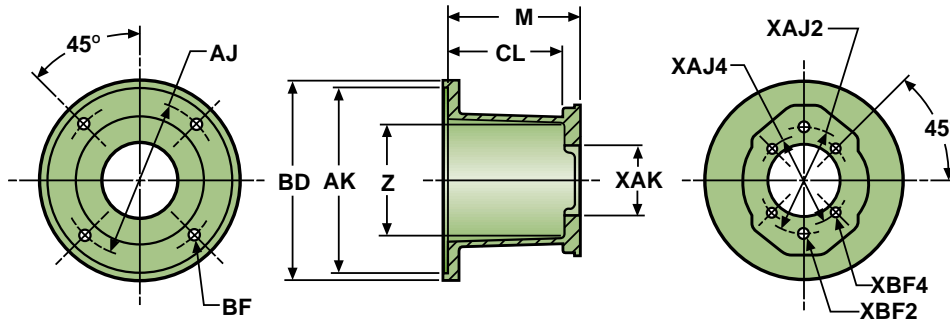

TABLE 8A - NEMA Frames 182TC - 256TC, 213UC-256UC

Horizontal Mounting (or Vertical Mounting - Option A)

RADIAL CLEARANCE "Z" = 5.00

182-A Casting



| MOTOR END DATA | | PUMP END DATA | | | | | MOUNT NO. CL M | | | MOUNT NO. CL M | | | MOUNT NO. CL M | | | | |
|----------------|-----------|---------------|-------|---------|-------|--------|----------------|---------|------------|----------------|------|------------|----------------|------|------------|------|------|
| AJ | BF | BD | AK | XAK | XAJ2 | XBF2 | XAJ4 | XBF4 | MOUNT NO. | CL | M | MOUNT NO. | CL | M | MOUNT NO. | CL | M |
| 7/25 | 17/32 | 9.00 | 8.501 | | | | | | | | | | | | | | |
| USA4F17 | 4 Bolt | | | 1.782 | | | 2.84 | 5/16-18 | M182474F | 4.00 | 4.75 | M182504F | 4.31 | 5.00 | M182524F | 4.31 | 5.25 |
| SAE AA | 2 Bolt | | | 2.001 | 3.25 | 3/8-16 | | | M182472AA | 4.00 | 4.75 | M182502AA | 4.31 | 5.00 | M182522AA | 4.31 | 5.25 |
| SAE A | 2(4) Bolt | | | 3.251 | 4.19 | 3/8-16 | 4.12 | 3/8-16 | M182472A | 4.00 | 4.75 | M182502A | 4.31 | 5.00 | M182522A | 4.31 | 5.25 |
| 80 A2/B4 | 2(4) Bolt | | | 80.01mm | 109mm | 3/8-16 | 103mm | 5/16-18 | M1824780M | 4.00 | 4.75 | M1825080M | 4.31 | 5.00 | M1825280M | 4.31 | 5.25 |
| 80 S4 | 4 Bolt | | | 80.01mm | | | 100mm | 5/16-18 | M1824780MS | 4.00 | 4.75 | M1825080MS | 4.31 | 5.00 | M1825280MS | 4.31 | 5.25 |
| PUMP FLANGE | | PUMP END DATA | | | | | 4.75 LENGTH | | | 5.00 LENGTH | | | 5.25 LENGTH | | | | |

| MOTOR END DATA | | PUMP END DATA | | | | | MOUNT NO. CL M | | | MOUNT NO. CL M | | | | |
|----------------|-----------|---------------|-------|---------|-------|--------|----------------|---------|------------|----------------|------|------------|------|------|
| AJ | BF | BD | AK | XAK | XAJ2 | XBF2 | XAJ4 | XBF4 | MOUNT NO. | CL | M | MOUNT NO. | CL | M |
| 7/25 | 17/32 | 9.00 | 8.501 | | | | | | | | | | | |
| USA4F17 | 4 Bolt | | | 1.782 | | | 2.84 | 5/16-18 | M182584F | 5.06 | 5.81 | M182684F | 6.06 | 6.81 |
| SAE AA | 2 Bolt | | | 2.001 | 3.25 | 3/8-16 | | | M182582AA | 5.06 | 5.81 | M182682AA | 6.06 | 6.81 |
| SAE A | 2(4) Bolt | | | 3.251 | 4.19 | 3/8-16 | 4.12 | 3/8-16 | M182582A | 5.06 | 5.81 | M182682A | 6.06 | 6.81 |
| 80 A2/B4 | 2(4) Bolt | | | 80.01mm | 109mm | 3/8-16 | 103mm | 5/16-18 | M1825880M | 5.06 | 5.81 | M1826880M | 6.06 | 6.81 |
| 80 S4 | 4 Bolt | | | 80.01mm | | | 100mm | 5/16-18 | M1825880MS | 5.06 | 5.81 | M1826880MS | 6.06 | 6.81 |
| PUMP FLANGE | | PUMP END DATA | | | | | 5.81 LENGTH | | | 6.81 LENGTH | | | | |

TABLE 8B - NEMA Frames 182TC - 256TC, 213UC-256UC

Horizontal Mounting

RADIAL CLEARANCE "Z" = 5.00

182-A Casting



| MOTOR END DATA | | PUMP END DATA | | | | | MOUNT NO. CL M | | | MOUNT NO. CL M | | | MOUNT NO. CL M | | | | |
|----------------|-----------|---------------|-------|----------|-------|--------|----------------|--------|------------|----------------|------|------------|----------------|------|------------|------|------|
| AJ | BF | BD | AK | XAK | XAJ2 | XBF2 | XAJ4 | XBF4 | MOUNT NO. | CL | M | MOUNT NO. | CL | M | MOUNT NO. | CL | M |
| 7/25 | 17/32 | 9.00 | 8.501 | | | | | | | | | | | | | | |
| SAE B | 2(4) Bolt | | | 4.001 | 5.75 | 1/2-13 | 5.00 | 1/2-13 | M182522B | 4.50 | 5.25 | M182582B | 5.06 | 5.81 | M182602B | 5.25 | 6.00 |
| SAE C | 2(4) Bolt | | | 5.001 | 7.12 | 5/8-11 | 6.38 | 1/2-13 | M182522C | 4.50 | 5.25 | M182582C | 5.06 | 5.81 | M182602C | 5.25 | 6.00 |
| 100 A2/B4 | 2(4) Bolt | | | 100.01mm | 140mm | 1/2-13 | 125mm | 3/8-16 | M18252100M | 4.50 | 5.25 | M18258100M | 5.06 | 5.81 | M18260100M | 5.25 | 6.00 |
| 125 A2/B4 | 2(4) Bolt | | | 125.01mm | 180mm | 5/8-11 | 160mm | 1/2-13 | M18252125M | 4.50 | 5.25 | M18258125M | 5.06 | 5.81 | M18260125M | 5.25 | 6.00 |
| PUMP FLANGE | | PUMP END DATA | | | | | 5.25 LENGTH | | | 5.81 LENGTH | | | 6.00 LENGTH | | | | |

Horizontal Pump/Motor Mounts



MOTOR END DATA

RADIAL CLEARANCE "Z" = 5.00

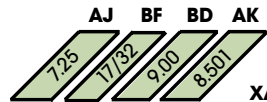

| | | XAK | XAJ2 | XBF2 | XAJ4 | XBF4 | MOUNT NO. | CL | M | MOUNT NO. | CL | M |
|-----------|-----------|----------|-------|--------|-------|--------|------------|------|------|------------|------|------|
| SAE B | 2(4) Bolt | 4.001 | 5.75 | 1/2-13 | 5.00 | 1/2-13 | M182682B | 6.06 | 6.81 | M182702B | 6.25 | 7.00 |
| SAE C | 2(4) Bolt | 5.001 | 7.12 | 5/8-11 | 6.38 | 1/2-13 | M182682C | 6.06 | 6.81 | M182702C | 6.25 | 7.00 |
| 100 A2/B4 | 2(4) Bolt | 100.01mm | 140mm | 1/2-13 | 125mm | 3/8-16 | M18268100M | 6.06 | 6.81 | M18270100M | 6.25 | 7.00 |
| 125 A2/B4 | 2(4) Bolt | 125.01mm | 180mm | 5/8-11 | 160mm | 1/2-13 | M18268125M | 6.06 | 6.81 | M18270125M | 6.25 | 7.00 |

PUMP FLANGE

PUMP END DATA

6.81 LENGTH

7.00 LENGTH

TABLE 9 - NEMA Frames 284TC/TSC - 286TC/TSC, 284UC/286UC

MOTOR END DATA

RADIAL CLEARANCE "Z" = 6.40

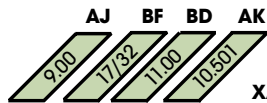

| | | XAK | XAJ2 | XBF2 | XAJ4 | XBF4 | MOUNT NO. | CL | M | MOUNT NO. | CL | M | MOUNT NO. | CL | M |
|-----------|-----------|----------|-------|--------|-------|---------|------------|------|------|------------|------|------|------------|------|------|
| SAE A | 2(4) Bolt | 3.25 | 4.19 | 3/8-16 | 4.12 | 3/8-16 | M284682A | 6.00 | 6.88 | M284752A | 6.62 | 7.50 | M284862A | 7.81 | 8.69 |
| SAE B | 2(4) Bolt | 4.001 | 5.75 | 1/2-13 | 5.00 | 1/2-13 | M284682B | 6.00 | 6.88 | M284752B | 6.62 | 7.50 | M284862B | 7.81 | 8.69 |
| SAE C | 2(4) Bolt | 5.001 | 7.12 | 5/8-11 | 6.38 | 1/2-13 | M284682C | 6.00 | 6.88 | M284752C | 6.62 | 7.50 | M284862C | 7.81 | 8.69 |
| 80 A2/B4 | 2(4) Bolt | 80.01mm | 109mm | 3/8-16 | 103mm | 5/16-18 | M2846880M | 6.00 | 6.88 | M2847580M | 6.62 | 7.50 | M2848680M | 7.81 | 8.69 |
| 80 S4 | 4 Bolt | 80.01mm | | | 100mm | 5/16-18 | M2846880MS | 6.00 | 6.88 | M2847580MS | 6.62 | 7.50 | M2848680MS | 7.81 | 8.69 |
| 100 A2/B4 | 2(4) Bolt | 100.01mm | 140mm | 1/2-13 | 125mm | 3/8-16 | M28468100M | 6.00 | 6.88 | M28475100M | 6.62 | 7.50 | M28486100M | 7.81 | 8.69 |
| 125 A2/B4 | 2(4) Bolt | 125.01mm | 180mm | 5/8-11 | 160mm | 1/2-13 | M28468125M | 6.00 | 6.88 | M28475125M | 6.62 | 7.50 | M28486125M | 7.81 | 8.69 |

PUMP FLANGE

PUMP END DATA

6.88 LENGTH

7.50 LENGTH

8.69 LENGTH

TABLE 10 - NEMA Frames 324TC/TSC - 405TC/TSC, 324UC/USC - 405UC/USC

MOTOR END DATA

RADIAL CLEARANCE "Z" = 7.74

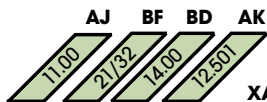

| | | XAK | XAJ2 | XBF2 | XAJ4 | XBF4 | MOUNT NO. | CL | M | MOUNT NO. | CL | M |
|-----------|-----------|----------|-------|--------|-------|--------|------------|------|------|------------|------|------|
| SAE B | 2(4) Bolt | 4.001 | 5.75 | 1/2-13 | 5.00 | 1/2-13 | M324762B | 6.75 | 7.62 | M324872B | 7.88 | 8.75 |
| SAE C | 2(4) Bolt | 5.001 | 7.12 | 5/8-11 | 6.38 | 1/2-13 | M324762C | 6.75 | 7.62 | M324872C | 7.88 | 8.75 |
| SAE D | 2(4) Bolt | 6.001 | 9.00 | 3/4-10 | 9.00 | 3/4-10 | M324762D | 6.75 | 7.62 | M324872D | 7.88 | 8.75 |
| 100 A2/B4 | 2(4) Bolt | 100.01mm | 140mm | 1/2-13 | 125mm | 3/8-16 | M32476100M | 6.75 | 7.62 | M32487100M | 7.88 | 8.75 |
| 125 A2/B4 | 2(4) Bolt | 125.01mm | 180mm | 5/8-11 | 160mm | 1/2-13 | M32476125M | 6.75 | 7.62 | M32487125M | 7.88 | 8.75 |
| 160 A2/B4 | 2(4) Bolt | 160.01mm | 224mm | 3/4-10 | 200mm | 5/8-11 | M32476160M | 6.75 | 7.62 | M32487160M | 7.88 | 8.75 |
| 180 B4 | 4 Bolt | 180.01mm | | | 224mm | 5/8-11 | M32476180M | 6.75 | 7.62 | M32487180M | 7.88 | 8.75 |

PUMP FLANGE

PUMP END DATA

7.62 LENGTH

8.75 LENGTH

TABLE 11 - NEMA Frames 444TC/TSC - 449TC/TSC, 444UC/USC - 445UC/USC

MOTOR END DATA

RADIAL CLEARANCE "Z" = 10.75

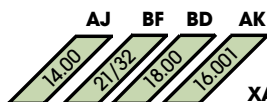

| | | XAK | XAJ2 | XBF2 | XAJ4 | XBF4 | MOUNT NO. | CL | M |
|-------|-----------|-------|-------|--------|------|--------|-----------|------|------|
| SAE C | 2(4) Bolt | 5.001 | 7.12 | 5/8-11 | 6.38 | 1/2-13 | M444882C | 7.12 | 8.88 |
| SAE D | 2(4) Bolt | 6.001 | 9.00 | 3/4-10 | 9.00 | 3/4-10 | M444882D | 7.12 | 8.88 |
| SAE E | 2 Bolt | 6.501 | 12.50 | 1-8 | | | M444882E | 7.12 | 8.88 |

PUMP FLANGE

PUMP END DATA

8.88 LENGTH



MAGNALOY'S VERTICAL PUMP/MOTOR MOUNTS are designed to allow direct mounting through the reservoir top. The pump and motor assembly is enclosed inside the reservoir resulting in a safer, quieter, more compact installation. Vertical mounts are available in NEMA C'face motor frame sizes 56C through 256TC to most SAE and Metric 2 and 4 bolt pump flanges. Two mounting options are available to give added flexibility in vertical power unit design.

A MOUNT KIT is included which contains all bolts and washers required to attach the pump and motor to the mount. The kit DOES NOT contain hardware for attaching the mount to the reservoir.



Vertical Mount Selection Method

1. Check TABLES 2 thru 5 to determine pump flange size.
2. Measure the pump shaft length from the shaft end to the flange mounting face and ADD to the motor shaft length shown in TABLE 6. An additional 1/16 inch (minimum) is recommended for shaft end clearance.
3. Determine mounting option desired as shown in Illustrations B, C, D and E depending on the NEMA frame size.
4. Refer to the appropriate TABLE (7, 8A, 12 or 13) according to NEMA motor frame size and locate the applicable pump flange selection from STEP 1, above. NOTE, Option A for vertical mounting NEMA 182TC thru 256TC is applicable ONLY to SAE-A and smaller pump flanges.
5. Select the mount length option (dimension "XM" or "M" in tables) based on the minimum length determined in STEP 2, above.
6. Check for proper clearance between the mount inner surfaces and the coupling O.D. (dimension "Z" and "CL" in tables). Dimensional data for Magnaloy Couplings is shown in TABLE 1 for reference. A complete Magnaloy Coupling catalog is available upon request.

NEMA Frame 56C thru 145TC Vertical Mounting

OPTION A

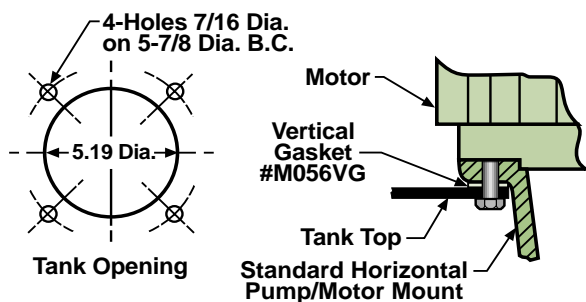

Illustration B

This economical vertical mounting option allows Tank Top Drop-thru mounting for ease of assembly and utilizes the standard horizontal mount and a sealing gasket.

To order OPTION A, specify the Horizontal Pump/Motor Mount number from TABLE 7 and Vertical Gasket number M056VG.

OPTION B

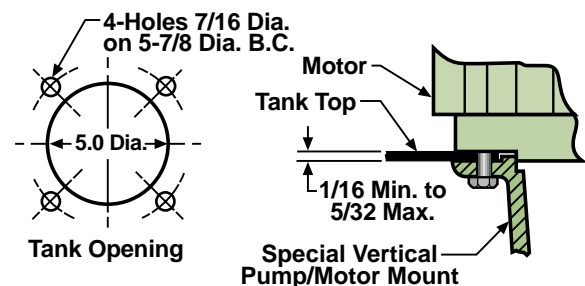

Illustration C

This mounting option requires inside tank access to position the mount/pump sub-assembly through the tank top opening.

To order OPTION B, specify the Vertical Pump/Motor Mount number from TABLE 12 followed with the letter 'V' as shown in TABLE 12. No gasket is required with this mounting option.

TABLE 12 - NEMA Frames 56C, 143TC/145TC, 182UC/184UC



| MOTOR END DATA | | | | | | RADIAL CLEARANCE "Z" = 4.15 | | | | | | | | | | | |
|----------------|-----------|---------|-------|--------|-------|-----------------------------|-------------|------|------|-------------|------|------|-------------|-----------|------|----|----|
| AJ | BF | BD | AK | | | MOUNT NO. | | CL | XM | MOUNT NO. | | CL | XM | MOUNT NO. | | CL | XM |
| 5.88 | 7.16 | 6.81 | 4.501 | XAK | XAJ2 | XBF2 | XAJ4 | XBF4 | | | | | | | | | |
| USA4F17 | 4 Bolt | 1.782 | | | 2.84 | 5/16-18 | M056354FV | 2.81 | 3.50 | M056424FV | 3.56 | 4.25 | M056454FV | 3.81 | 4.50 | | |
| SAE AA | 2 Bolt | 2.001 | 3.25 | 3/8-16 | | | M056352AAV | 2.81 | 3.50 | M056422AAV | 3.56 | 4.25 | M056452AAV | 3.81 | 4.50 | | |
| SAE A | 2(4) Bolt | 3.251 | 4.19 | 3/8-16 | 4.12 | 3/8-16 | M056352AV | 2.81 | 3.50 | M056422AV | 3.56 | 4.25 | M056452AV | 3.81 | 4.50 | | |
| 80 A2/B4 | 2(4) Bolt | 80.01mm | 109mm | 3/8-16 | 103mm | 5/16-18 | M0563580MV | 2.81 | 3.50 | M0564280MV | 3.56 | 4.25 | M0564580MV | 3.81 | 4.50 | | |
| 80 S4 | 4 Bolt | 80.01mm | | | 100mm | 5/16-18 | M0563580MSV | 2.81 | 3.50 | M0564280MSV | 3.56 | 4.25 | M0564580MSV | 3.81 | 4.50 | | |

| MOTOR END DATA | | | | | | RADIAL CLEARANCE "Z" = 4.15 *RADIAL CLEARANCE "Z" = 4.10 | | | | | | NOTE: See drawing top of page 10 for dimensional reference | | |
|----------------|-----------|----------|-------|--------|-------|---|--------------|------|------|--------------|------|--|----|----|
| AJ | BF | BD | AK | | | MOUNT NO. | | CL | XM | MOUNT NO. | | | CL | XM |
| 5.88 | 7.16 | 6.81 | 4.501 | XAK | XAJ2 | XBF2 | XAJ4 | XBF4 | | | | | | |
| USA4F17 | 4 Bolt | 1.782 | | | 2.84 | 5/16-18 | M056504FV | 4.31 | 5.00 | M056524FV | 4.56 | 5.25 | | |
| SAE AA | 2 Bolt | 2.001 | 3.25 | 3/8-16 | | | M056502AAV | 4.31 | 5.00 | M056522AAV | 4.56 | 5.25 | | |
| SAE A | 2(4) Bolt | 3.251 | 4.19 | 3/8-16 | 4.12 | 3/8-16 | M056502AV | 4.31 | 5.00 | M056522AV | 4.56 | 5.25 | | |
| SAE B | 2(4) Bolt | 4.001 | 5.75 | 1/2-13 | 5.00 | 1/2-13 | M056502BV* | 3.93 | 5.00 | M056522BV* | 4.18 | 5.25 | | |
| 80 A2/B4 | 2(4) Bolt | 80.01mm | 109mm | 3/8-16 | 103mm | 5/16-18 | M0565080MV | 4.31 | 5.00 | M0565280MV | 4.56 | 5.25 | | |
| 80 S4 | 4 Bolt | 80.01mm | | | 100mm | 5/16-18 | M0565080MSV | 4.31 | 5.00 | M0565280MSV | 4.56 | 5.25 | | |
| 100 A2/B4 | 2(4) Bolt | 100.01mm | 140mm | 1/2-13 | 125mm | 3/8-16 | M05650100MV* | 3.93 | 5.00 | M05652100MV* | 4.18 | 5.25 | | |

NEMA Frame 182TC thru 256TC Vertical Mounting

OPTION A

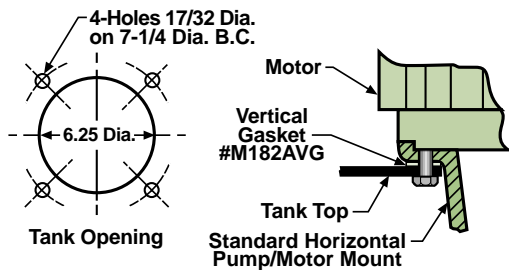

Illustration D

This mounting option offers an economical alternative to OPTION B, but is available with SAE-A pump flanges and smaller only. OPTION A utilizes the standard horizontal mount and a sealing gasket.

To order OPTION A, specify the Horizontal Pump/Motor Mount number from TABLE 8A and Vertical Gasket number M182AVG.

OPTION B

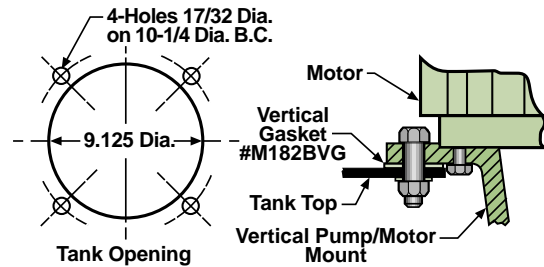

Illustration E

This option utilizes an oversize mounting flange on the motor end of the mount and requires a larger diameter tank top opening giving additional working clearances for assembly to reservoir. Mounting OPTION B is available in the pump/motor length combinations shown in TABLE 13.

To order OPTION B, specify the Vertical Pump/Motor Mount number from TABLE 13 followed with the letter 'V', as shown in TABLE 13. The required Vertical Gasket number M182BVG is included.

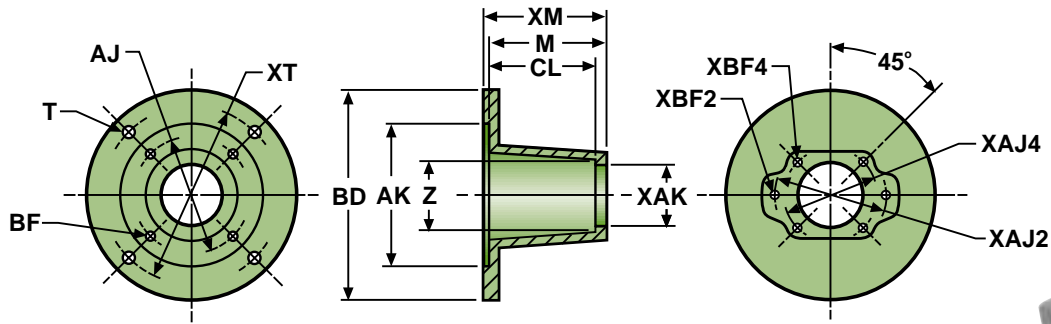
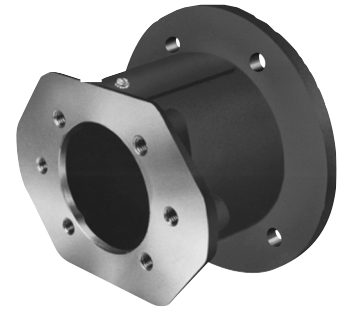

TABLE 13 - NEMA Frames 182TC - 256TC, 213UC/256UC

| MOTOR END DATA | | | | | | | RADIAL CLEARANCE "Z" = 5.00 | | | | | | | | | | |
|--------------------|-----------|-------|-------|----------------------|-------|--------|-----------------------------|--------------------|-------------|------|--------------------|-------------|------|--------------------|-------------|------|------|
| AJ | BF | BD | AK | XAK | XAJ2 | XBF2 | XAJ4 | XBF4 | MOUNT NO. | CL | M | MOUNT NO. | CL | M | MOUNT NO. | CL | M |
| 7/25 | 17/32 | 11.50 | 8.501 | | | | | | | | | | | | | | |
| USA4F17 | 4 Bolt | | | 1.782 | | | 2.84 | 5/16-18 | M182504FV | 4.31 | 5.00 | M182524FV | 4.31 | 5.25 | M182584FV | 5.06 | 5.81 |
| SAE AA | 2 Bolt | | | 2.001 | 3.25 | 3/8-16 | | | M182502AAV | 4.31 | 5.00 | M182522AAV | 4.31 | 5.25 | M182582AAV | 5.06 | 5.81 |
| SAE A | 2(4) Bolt | | | 3.251 | 4.19 | 3/8-16 | 4.12 | 3/8-16 | M182502AV | 4.31 | 5.00 | M182522AV | 4.31 | 5.25 | M182582AV | 5.06 | 5.81 |
| SAE B | 2(4) Bolt | | | 4.001 | 5.75 | 1/2-13 | 5.00 | 1/2-13 | | | | M182522BV | 4.50 | 5.25 | M182582BV | 5.06 | 5.81 |
| SAE C | 2(4) Bolt | | | 5.001 | 7.12 | 5/8-11 | 6.38 | 1/2-13 | | | | M182522CV | 4.50 | 5.25 | M182582CV | 5.06 | 5.81 |
| 80 A2/B4 | 2(4) Bolt | | | 80.01mm | 109mm | 3/8-16 | 103mm | 5/16-18 | M1825080MV | 4.31 | 5.00 | M1825280MV | 4.31 | 5.25 | M1825880MV | 5.06 | 5.81 |
| 80 S4 | 4 Bolt | | | 80.01mm | | | 100mm | 5/16-18 | M1825080MSV | 4.31 | 5.00 | M1825280MSV | 4.31 | 5.25 | M1825880MSV | 5.06 | 5.81 |
| 100 A2/B4 | 2(4) Bolt | | | 100.01mm | 140mm | 1/2-13 | 125mm | 3/8-16 | | | | M18252100MV | 4.50 | 5.25 | M18258100MV | 5.06 | 5.81 |
| 125 A2/B4 | 2(4) Bolt | | | 125.01mm | 180mm | 5/8-11 | 160mm | 1/2-13 | | | | M18252125MV | 4.50 | 5.25 | M18258125MV | 5.06 | 5.81 |
| PUMP FLANGE | | | | PUMP END DATA | | | | 5.00 LENGTH | | | 5.25 LENGTH | | | 5.81 LENGTH | | | |

| MOTOR END DATA | | | | | | | RADIAL CLEARANCE "Z" = 5.00 | | | | | | | | | | |
|--------------------|-----------|-------|-------|----------------------|-------|--------|-----------------------------|--------------------|-------------|------|--------------------|-------------|------|------|-----------|----|---|
| AJ | BF | BD | AK | XAK | XAJ2 | XBF2 | XAJ4 | XBF4 | MOUNT NO. | CL | M | MOUNT NO. | CL | M | MOUNT NO. | CL | M |
| 7/25 | 17/32 | 11.50 | 8.501 | | | | | | | | | | | | | | |
| USA4F17 | 4 Bolt | | | 1.782 | | | 2.84 | 5/16-18 | M182684FV | 6.06 | 6.81 | | | | | | |
| SAE AA | 2 Bolt | | | 2.001 | 3.25 | 3/8-16 | | | M182682AAV | 6.06 | 6.81 | | | | | | |
| SAE A | 2(4) Bolt | | | 3.251 | 4.19 | 3/8-16 | 4.12 | 3/8-16 | M182682AV | 6.06 | 6.81 | | | | | | |
| SAE B | 2(4) Bolt | | | 4.001 | 5.75 | 1/2-13 | 5.00 | 1/2-13 | M182682BV | 6.06 | 6.81 | M182702BV | 6.25 | 7.00 | | | |
| SAE C | 2(4) Bolt | | | 5.001 | 7.12 | 5/8-11 | 6.38 | 1/2-13 | M182682CV | 6.06 | 6.81 | M182702CV | 6.25 | 7.00 | | | |
| 80 A2/B4 | 2(4) Bolt | | | 80.01mm | 109mm | 3/8-16 | 103mm | 5/16-18 | M1826880MV | 6.06 | 6.81 | | | | | | |
| 80 S4 | 4 Bolt | | | 80.01mm | | | 100mm | 5/16-18 | M1826880MSV | 6.06 | 6.81 | | | | | | |
| 100 A2/B4 | 2(4) Bolt | | | 100.01mm | 140mm | 1/2-13 | 125mm | 3/8-16 | M18268100MV | 6.06 | 6.81 | M18270100MV | 6.25 | 7.00 | | | |
| 125 A2/B4 | 2(4) Bolt | | | 125.01mm | 180mm | 5/8-11 | 160mm | 1/2-13 | M18268125MV | 6.06 | 6.81 | M18270125MV | 6.25 | 7.00 | | | |
| PUMP FLANGE | | | | PUMP END DATA | | | | 6.81 LENGTH | | | 7.00 LENGTH | | | | | | |

MAGNALOY'S PUMP/ENGINE MOUNTS are available for mounting SAE flange-mount pumps to gasoline and diesel engines with pilot mounting capabilities. Four basic engine pilot mounting configurations are available from inventory determined by the pilot diameter. Optional sizes are available upon request.



Engine Mount Selection Method

1. Check TABLES 2 thru 5 to determine pump flange size.
2. Determine Engine Pilot Group from TABLE 14 (other sizes available, consult factory).
3. Measure the pump shaft length from the shaft end to the flange mounting face and ADD to the engine shaft length measured from shaft end to pilot face. An additional 1/16 inch (minimum) is recommended for shaft end clearance.
4. Refer to the appropriate TABLE (15 thru 18) according to Engine Pilot Group determined in STEP 2, above and locate the applicable pump flange selection from STEP 1, above.
5. Select mount length option (dimension "XM" in tables) based on the minimum length determined in STEP 3, above.
6. Check for proper clearance between the mount inner surfaces and the coupling O.D. (dimension "Z" and "CL" in tables). Dimensional data for Magnaloy Couplings is shown in TABLE 1 for reference. A complete Magnaloy Coupling catalog is available upon request.

TABLE 14 - Engine Pilot Groups

| Size | K | J |
|------|-------|------|
| E575 | 5.75 | 6.50 |
| E644 | 6.437 | 7.75 |
| E700 | 7.00 | 7.75 |
| E787 | 7.875 | 9.25 |

Pilot Group Pilot Ø Bolt Circle Ø

TABLE 15 - E575 Pilot Gasoline and Diesel Engines

| ENGINE END DATA | | PUMP END DATA | | | | | 5.00 LENGTH | | | 5.25 LENGTH | | | 6.00 LENGTH ** | | | | |
|-----------------|-------|---------------|-------|-----|------|------|-------------|------|-------------|-------------|------|-------------|----------------|------|------------|------|------|
| AJ | BF | BD | AK | XAK | XAJ2 | XBF2 | XAJ4 | XBF4 | MOUNT NO. | CL | XM | MOUNT NO. | CL | XM | MOUNT NO. | CL | XM |
| 6.50 | 13/32 | 7.50 | 5.752 | | | | | | E575504F | 4.31 | 5.00 | E575524F | 4.56 | 5.25 | E575604F | 5.14 | 6.00 |
| | | | | | | | | | E575502AA | 4.31 | 5.00 | E575522AA | 4.56 | 5.25 | E575602AA | 5.14 | 6.00 |
| | | | | | | | | | E575502A | 4.31 | 5.00 | E575522A | 4.56 | 5.25 | E575602A | 5.14 | 6.00 |
| | | | | | | | | | E575502B* | 3.93 | 5.00 | E575522B* | 4.18 | 5.25 | E575602B | 5.14 | 6.00 |
| | | | | | | | | | E5755080M | 4.31 | 5.00 | E5755280M | 4.56 | 5.25 | E5756080M | 5.14 | 6.00 |
| | | | | | | | | | E5755080MS | 4.31 | 5.00 | E5755280MS | 4.56 | 5.25 | E5756080MS | 5.14 | 6.00 |
| | | | | | | | | | E57550100M* | 3.93 | 5.00 | E57552100M* | 4.18 | 5.25 | E57560100M | 5.14 | 6.00 |

ENGINE END DATA: AJ, BF, BD, AK
 RADIAL CLEARANCE "Z" = 4.15 "Z" = 4.15 "Z" = 5.00
 *RADIAL CLEARANCE "Z" = 4.10 *"Z" = 4.10

** SOCKET HEAD CAP SCREWS REQUIRED ON ENGINE END - THIS LENGTH ONLY.

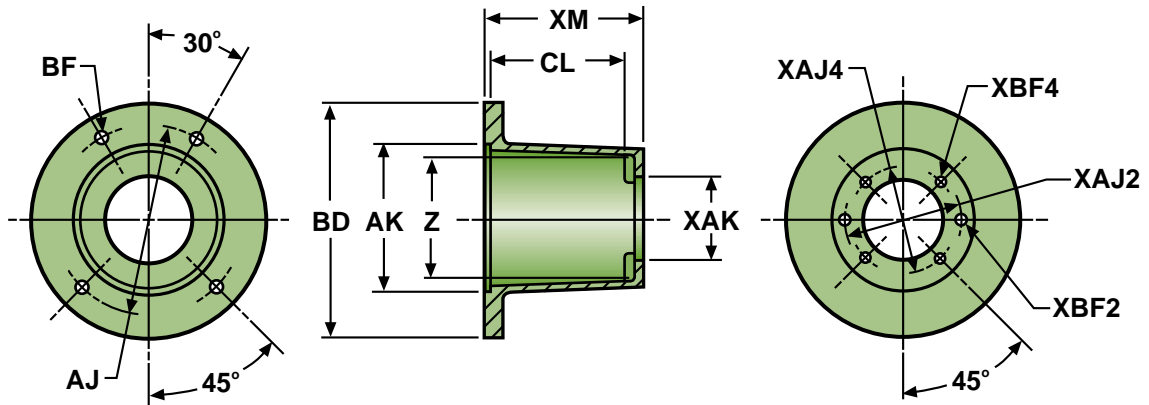

TABLE 16 - E644 Pilot Gasoline and Diesel Engines



ENGINE END DATA

| | AJ | BF | BD | AK |
|-------|----|----|----|----|
| 7/16 | | | | |
| 1 1/8 | | | | |
| 9/16 | | | | |
| 6.439 | | | | |

RADIAL CLEARANCE "Z" = 5.00

| | XAK | XAJ2 | XBF2 | XAJ4 | XBF4 | MOUNT NO. | CL | XM | MOUNT NO. | CL | XM |
|------------------|-----------|----------|-------|--------|---------------|-------------------|------|------|-------------------|------|------|
| USA4F17 | 4 Bolt | 1.782 | | 2.84 | 5/16-18 | E644504F | 4.05 | 5.00 | E644554F | 4.36 | 5.50 |
| SAE AA | 2 Bolt | 2.001 | 3.25 | 3/8-16 | | E644502AA | 4.05 | 5.00 | E644552AA | 4.36 | 5.50 |
| SAE A | 2(4) Bolt | 3.251 | 4.19 | 3/8-16 | 4.12 3/8-16 | E644502A | 4.05 | 5.00 | E644552A | 4.36 | 5.50 |
| SAE B | 2(4) Bolt | 4.001 | 5.75 | 1/2-13 | 5.00 1/2-13 | | | | E644552B | 4.36 | 5.50 |
| 80 A2/B4 | 2(4) Bolt | 80.01mm | 109mm | 3/8-16 | 103mm 5/16-18 | E6445080M | 4.05 | 5.00 | E6445580M | 4.36 | 5.50 |
| 80 S4 | 4 Bolt | 80.01mm | | | 100mm 5/16-18 | E6445080MS | 4.05 | 5.00 | E6445580MS | 4.36 | 5.50 |
| 100 A2/B4 | 2(4) Bolt | 100.01mm | 140mm | 1/2-13 | 125mm 3/8-16 | | | | E64455100M | 4.36 | 5.50 |

PUMP FLANGE **PUMP END DATA** **5.00 LENGTH** **5.50 LENGTH**

ENGINE END DATA

| | AJ | BF | BD | AK |
|-------|----|----|----|----|
| 7/16 | | | | |
| 1 1/8 | | | | |
| 9/16 | | | | |
| 6.439 | | | | |

RADIAL CLEARANCE "Z" = 5.00

| | XAK | XAJ2 | XBF2 | XAJ4 | XBF4 | MOUNT NO. | CL | XM | MOUNT NO. | CL | XM | MOUNT NO. | CL | XM |
|------------------|-----------|----------|-------|--------|---------------|-------------------|------|------|-------------------|------|------|-------------------|------|------|
| USA4F17 | 4 Bolt | 1.782 | | 2.84 | 5/16-18 | E644604F | 5.11 | 6.00 | E644704F | 6.11 | 7.00 | | | |
| SAE AA | 2 Bolt | 2.001 | 3.25 | 3/8-16 | | E644602AA | 5.11 | 6.00 | E644702AA | 6.11 | 7.00 | | | |
| SAE A | 2(4) Bolt | 3.251 | 4.19 | 3/8-16 | 4.12 3/8-16 | E644602A | 5.11 | 6.00 | E644702A | 6.11 | 7.00 | | | |
| SAE B | 2(4) Bolt | 4.001 | 5.75 | 1/2-13 | 5.00 1/2-13 | E644602B | 5.11 | 6.00 | E644702B | 6.11 | 7.00 | E644722B | 6.31 | 7.25 |
| SAE C | 2(4) Bolt | 5.001 | 7.12 | 5/8-11 | 6.38 1/2-13 | E644602C | 5.11 | 6.00 | E644702C | 6.11 | 7.00 | E644722C | 6.31 | 7.25 |
| 80 A2/B4 | 2(4) Bolt | 80.01mm | 109mm | 3/8-16 | 103mm 5/16-18 | E6446080M | 5.11 | 6.00 | E6447080M | 6.11 | 7.00 | | | |
| 80 S4 | 4 Bolt | 80.01mm | | | 100mm 5/16-18 | E6446080MS | 5.11 | 6.00 | E6447080MS | 6.11 | 7.00 | | | |
| 100 A2/B4 | 2(4) Bolt | 100.01mm | 140mm | 1/2-13 | 125mm 3/8-16 | E64460100M | 5.11 | 6.00 | E64470100M | 6.11 | 7.00 | E64472100M | 6.31 | 7.25 |
| 125 A2/B4 | 2(4) Bolt | 125.01mm | 180mm | 5/8-11 | 160mm 1/2-13 | E64460125M | 5.11 | 6.00 | E64470125M | 6.11 | 7.00 | E64472125M | 6.31 | 7.25 |

PUMP FLANGE **PUMP END DATA** **6.00 LENGTH** **7.00 LENGTH** **7.25 LENGTH**



TABLE 17 - E700 Pilot Gasoline and Diesel Engines

ENGINE END DATA
AJ BF BD AK
7.75 15/32 9.00 7.002

RADIAL CLEARANCE "Z" = 5.00

| | | XAK | XAJ2 | XBF2 | XAJ4 | XBF4 | MOUNT NO. | CL | XM | MOUNT NO. | CL | XM |
|-----------|-----------|----------|-------|--------|-------|---------|------------|------|------|------------|------|------|
| USA4F17 | 4 Bolt | 1.782 | | | 2.84 | 5/16-18 | E700504F | 4.05 | 5.00 | E700554F | 4.36 | 5.50 |
| SAE AA | 2 Bolt | 2.001 | 3.25 | 3/8-16 | | | E700502AA | 4.05 | 5.00 | E700552AA | 4.36 | 5.50 |
| SAE A | 2(4) Bolt | 3.251 | 4.19 | 3/8-16 | 4.12 | 3/8-16 | E700502A | 4.05 | 5.00 | E700552A | 4.36 | 5.50 |
| SAE B | 2(4) Bolt | 4.001 | 5.75 | 1/2-13 | 5.00 | 1/2-13 | | | | E700552B | 4.36 | 5.50 |
| 80 A2/B4 | 2(4) Bolt | 80.01mm | 109mm | 3/8-16 | 103mm | 5/16-18 | E7005080M | 4.05 | 5.00 | E7005580M | 4.36 | 5.50 |
| 80 S4 | 4 Bolt | 80.01mm | | | 100mm | 5/16-18 | E7005080MS | 4.05 | 5.00 | E7005580MS | 4.36 | 5.50 |
| 100 A2/B4 | 2(4) Bolt | 100.01mm | 140mm | 1/2-13 | 125mm | 3/8-16 | | | | E70455100M | 4.36 | 5.50 |

PUMP FLANGE PUMP END DATA 5.00 LENGTH 5.50 LENGTH

ENGINE END DATA
AJ BF BD AK
7.75 15/32 9.00 7.002

RADIAL CLEARANCE "Z" = 5.00

| | | XAK | XAJ2 | XBF2 | XAJ4 | XBF4 | MOUNT NO. | CL | XM | MOUNT NO. | CL | XM | MOUNT NO. | CL | XM |
|-----------|-----------|----------|-------|--------|-------|---------|------------|------|------|------------|------|------|------------|------|------|
| USA4F17 | 4 Bolt | 1.782 | | | 2.84 | 5/16-18 | E700604F | 5.11 | 6.00 | E700704F | 6.11 | 7.00 | | | |
| SAE AA | 2 Bolt | 2.001 | 3.25 | 3/8-16 | | | E700602AA | 5.11 | 6.00 | E700702AA | 6.11 | 7.00 | | | |
| SAE A | 2(4) Bolt | 3.251 | 4.19 | 3/8-16 | 4.12 | 3/8-16 | E700602A | 5.11 | 6.00 | E700702A | 6.11 | 7.00 | | | |
| SAE B | 2(4) Bolt | 4.001 | 5.75 | 1/2-13 | 5.00 | 1/2-13 | E700602B | 5.11 | 6.00 | E700702B | 6.11 | 7.00 | E700722B | 6.31 | 7.25 |
| SAE C | 2(4) Bolt | 5.001 | 7.12 | 5/8-11 | 6.38 | 1/2-13 | E700602C | 5.11 | 6.00 | E700702C | 6.11 | 7.00 | E700722C | 6.31 | 7.25 |
| 80 A2/B4 | 2(4) Bolt | 80.01mm | 109mm | 3/8-16 | 103mm | 5/16-18 | E7006080M | 5.11 | 6.00 | E7007080M | 6.11 | 7.00 | | | |
| 80 S4 | 4 Bolt | 80.01mm | | | 100mm | 5/16-18 | E7006080MS | 5.11 | 6.00 | E7007080MS | 6.11 | 7.00 | | | |
| 100 A2/B4 | 2(4) Bolt | 100.01mm | 140mm | 1/2-13 | 125mm | 3/8-16 | E70060100M | 5.11 | 6.00 | E70070100M | 6.11 | 7.00 | E70072100M | 6.31 | 7.25 |
| 125 A2/B4 | 2(4) Bolt | 125.01mm | 180mm | 5/8-11 | 160mm | 1/2-13 | E70060125M | 5.11 | 6.00 | E70070125M | 6.11 | 7.00 | E70072125M | 6.31 | 7.25 |

PUMP FLANGE PUMP END DATA 6.00 LENGTH 7.00 LENGTH 7.25 LENGTH

TABLE 18 - E787 Pilot Gasoline and Diesel Engines

ENGINE END DATA
AJ BF BD AK
9.25 2 11.00 7.877

RADIAL CLEARANCE "Z" = 6.40

| | | XAK | XAJ2 | XBF2 | XAJ4 | XBF4 | MOUNT NO. | CL | XM | MOUNT NO. | CL | XM | MOUNT NO. | CL | XM |
|-----------|-----------|----------|-------|--------|-------|---------|------------|------|------|------------|------|------|------------|------|------|
| SAE A | 2(4) Bolt | 3.251 | 4.19 | 3/8-16 | 4.12 | 3/8-16 | E787682A | 5.80 | 6.88 | E787752A | 6.42 | 7.50 | E787862A | 7.61 | 8.69 |
| SAE B | 2(4) Bolt | 4.001 | 5.75 | 1/2-13 | 5.00 | 1/2-13 | E787682B | 5.80 | 6.88 | E787752B | 6.42 | 7.50 | E787862B | 7.61 | 8.69 |
| SAE C | 2(4) Bolt | 5.001 | 7.12 | 5/8-11 | 6.38 | 1/2-13 | E787682C | 5.80 | 6.88 | E787752C | 6.42 | 7.50 | E787862C | 7.61 | 8.69 |
| 80 A2/B4 | 2(4) Bolt | 80.01mm | 109mm | 3/8-16 | 103mm | 5/16-18 | E7876880M | 5.80 | 6.88 | E7877580M | 6.42 | 7.50 | E7878680M | 7.61 | 8.69 |
| 80 S4 | 4 Bolt | 80.01mm | | | 100mm | 5/16-18 | E7876880MS | 5.80 | 6.88 | E7877580MS | 6.42 | 7.50 | E7878680MS | 7.61 | 8.69 |
| 100 A2/B4 | 2(4) Bolt | 100.01mm | 140mm | 1/2-13 | 125mm | 3/8-16 | E78768100M | 5.80 | 6.88 | E78775100M | 6.42 | 7.50 | E78786100M | 7.61 | 8.69 |
| 125 A2/B4 | 2(4) Bolt | 125.01mm | 180mm | 5/8-11 | 160mm | 1/2-13 | E78768125M | 5.80 | 6.88 | E78775125M | 6.42 | 7.50 | E78786125M | 7.61 | 8.69 |

PUMP FLANGE PUMP END DATA 6.88 LENGTH 7.50 LENGTH 8.69 LENGTH

MAGNALOY'S WELDED STEEL MOUNTS are available for special mounting requirements where the standard aluminum mount is not available or where a steel mount is required. These mounts are manufactured with the same quality and precision of the standard aluminum mounts and are guaranteed to meet Magnaloy's minimum quality measurements shown in Illustration A, page 2. Magnaloy's Welded Steel Mounts are available for horizontal, vertical and engine applications in a nearly limitless choice of lengths in 1/4 inch increments.



MOUNTING KITS are included as with the cast aluminum mounts.

Magnaloy Horizontal Welded Steel Pump/Motor Mounts

MAGNALOY'S HORIZONTAL WELDED STEEL MOUNTS are available for metric motor and metric pump dimensions in addition to NEMA motors and SAE pumps listed, consult factory for special requirements. To select a welded steel horizontal mount follow the selection method detailed on page 5. The length determined will be the minimum length recommended, additional length can be added depending upon coupling selection, consult factory for further assistance.

TABLE 19 - NEMA 56C, 143TC/145TC, 182UC/184UC

| MOTOR END DATA | | RADIAL CLEARANCE "Z" = 4.03 | | | | | | MOUNT NO. | | |
|----------------|-----------|-----------------------------|-------|-------|------|--------|------|-----------|------|-------------|
| AJ | BF | BD | AK | XAK | XAJ2 | XBF2 | XAJ4 | | XBF4 | XBD |
| 5.98 | 7/16 | 6.81 | 4.501 | | | | | | | |
| USA4F17 | 4 Bolt | | | 1.782 | | | 2.84 | 5/16-18 | 5.25 | S056 -- 4F |
| SAE AA | 2 Bolt | | | 2.001 | 3.25 | 3/8-16 | | | 5.25 | S056 -- 2AA |
| SAE A | 2(4) Bolt | | | 3.251 | 4.19 | 3/8-16 | 4.12 | 3/8-16 | 5.25 | S056 -- 2A |
| SAE B | 2(4) Bolt | | | 4.001 | 5.75 | 1/2-13 | 5.00 | 1/2-13 | 7.00 | S056 -- 2B |
| SAE C | 2(4) Bolt | | | 5.001 | 7.12 | 5/8-11 | 6.38 | 1/2-13 | 8.25 | S056 -- 2C |

(METRIC SIZES ALSO AVAILABLE)

TABLE 20 - NEMA 182TC - 256TC, 254UC/256UC

| MOTOR END DATA | | RADIAL CLEARANCE "Z" = 5.04 | | | | | | MOUNT NO. | | |
|----------------|-----------|-----------------------------|-------|-------|------|--------|------|-----------|-------|-------------|
| AJ | BF | BD | AK | XAK | XAJ2 | XBF2 | XAJ4 | | XBF4 | XBD |
| 7.25 | 17/32 | 9.00 | 8.501 | | | | | | | |
| USA4F17 | 4 Bolt | | | 1.782 | | | 2.84 | 5/16-18 | 6.00 | S182 -- 4F |
| SAE AA | 2 Bolt | | | 2.001 | 3.25 | 3/8-16 | | | 6.00 | S182 -- 2AA |
| SAE A | 2(4) Bolt | | | 3.251 | 4.19 | 3/8-16 | 4.12 | 3/8-16 | 6.00 | S182 -- 2A |
| SAE B | 2(4) Bolt | | | 4.001 | 5.75 | 1/2-13 | 5.00 | 1/2-13 | 7.00 | S182 -- 2B |
| SAE C | 2(4) Bolt | | | 5.001 | 7.12 | 5/8-11 | 6.38 | 1/2-13 | 8.25 | S182 -- 2C |
| SAE D | 2(4) Bolt | | | 6.001 | 9.00 | 3/4-10 | 9.00 | 3/4-10 | 10.50 | S182 -- 2D |

(METRIC SIZES ALSO AVAILABLE)

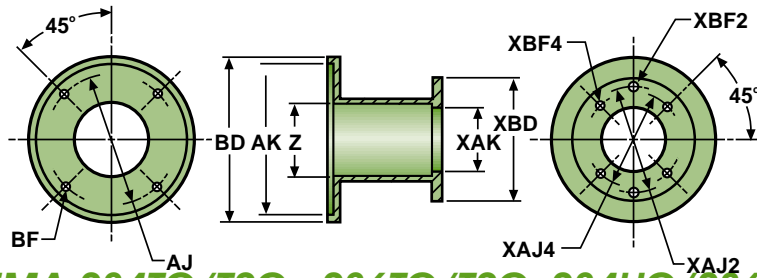

TABLE 21 - NEMA 284TC/TSC - 286TC/TSC, 284UC/286UC

RADIAL CLEARANCE "Z" = 6.06

| MOTOR END DATA | | PUMP END DATA | | | | | | MOUNT NO. | (METRIC SIZES ALSO AVAILABLE) | |
|----------------|-----------|---------------|--------|-------|-------|--------|-------|-----------|-------------------------------|-------------------|
| AJ | BF | BD | AK | XAK | XAJ2 | XBF2 | XAJ4 | | | XBF4 |
| 9.00 | 17/32 | 11.00 | 10.501 | | | | | | | |
| SAE A | 2(4) Bolt | | | 3.251 | 4.19 | 3/8-16 | 4.12 | 3/8-16 | 7.00 | S284 -- 2A |
| SAE B | 2(4) Bolt | | | 4.001 | 5.75 | 1/2-13 | 5.00 | 1/2-13 | 7.00 | S284 -- 2B |
| SAE C | 2(4) Bolt | | | 5.001 | 7.12 | 5/8-11 | 6.38 | 1/2-13 | 8.25 | S284 -- 2C |
| SAE D | 2(4) Bolt | | | 6.001 | 9.00 | 3/4-10 | 9.00 | 3/4-10 | 10.50 | S284 -- 2D |
| SAE E | 2(4) Bolt | | | 6.501 | 12.50 | 1-8 | 12.50 | 3/4-10 | 15.00 | S284 -- 2E |
| SAE F | 2(4) Bolt | | | 7.001 | 13.78 | 1-8 | 13.78 | 1-8 | 16.00 | S284 -- 2F |

TABLE 22 - NEMA 324TC/TSC - 405TC/TSC, 324UC/USC - 405UC/USC

RADIAL CLEARANCE "Z" (See Below)

| MOTOR END DATA | | PUMP END DATA | | | | | | | | MOUNT NO. | (METRIC SIZES ALSO AVAILABLE) |
|----------------|-----------|---------------|--------|-------|-------|--------|-------|--------|-------|-----------|-------------------------------|
| AJ | BF | BD | AK | XAK | XAJ2 | XBF2 | XAJ4 | XBF4 | XBD | | |
| 11.00 | 21/32 | 14.00 | 12.501 | | | | | | | | |
| SAE A | 2(4) Bolt | | | 3.251 | 4.19 | 3/8-16 | 4.12 | 3/8-16 | 9.25 | 7.98 | S324 -- 2A |
| SAE B | 2(4) Bolt | | | 4.001 | 5.75 | 1/2-13 | 5.00 | 1/2-13 | 9.25 | 7.98 | S324 -- 2B |
| SAE C | 2(4) Bolt | | | 5.001 | 7.12 | 5/8-11 | 6.38 | 1/2-13 | 9.25 | 7.98 | S324 -- 2C |
| SAE D | 2(4) Bolt | | | 6.001 | 9.00 | 3/4-10 | 9.00 | 3/4-10 | 10.50 | 7.98 | S324 -- 2D |
| SAE E | 2(4) Bolt | | | 6.501 | 12.50 | 1-8 | 12.50 | 3/4-10 | 15.00 | 7.98 | S324 -- 2E |
| SAE F | 2(4) Bolt | | | 7.001 | 13.78 | 1-8 | 13.78 | 1-8 | 16.00 | 9.00 | S324 -- 2F |

TABLE 23 - NEMA Frames 444TC/TSC - 449TC/TSC, 444UC/USC - 445UC/USC

RADIAL CLEARANCE "Z" = 10.02

| MOTOR END DATA | | PUMP END DATA | | | | | | MOUNT NO. | (METRIC SIZES ALSO AVAILABLE) | |
|----------------|-----------|---------------|--------|-------|-------|--------|-------|-----------|-------------------------------|-------------------|
| AJ | BF | BD | AK | XAK | XAJ2 | XBF2 | XAJ4 | | | XBF4 |
| 14.00 | 21/32 | 17.00 | 16.001 | | | | | | | |
| SAE A | 2(4) Bolt | | | 3.251 | 4.19 | 3/8-16 | 4.12 | 3/8-16 | 11.25 | S444 -- 2A |
| SAE B | 2(4) Bolt | | | 4.001 | 5.75 | 1/2-13 | 5.00 | 1/2-13 | 11.25 | S444 -- 2B |
| SAE C | 2(4) Bolt | | | 5.001 | 7.12 | 5/8-11 | 6.38 | 1/2-13 | 11.25 | S444 -- 2C |
| SAE D | 2(4) Bolt | | | 6.001 | 9.00 | 3/4-10 | 9.00 | 3/4-10 | 11.25 | S444 -- 2D |
| SAE E | 2(4) Bolt | | | 6.501 | 12.50 | 1-8 | 12.50 | 3/4-10 | 15.00 | S444 -- 2E |
| SAE F | 2(4) Bolt | | | 7.001 | 13.78 | 1-8 | 13.78 | 1-8 | 16.00 | S444 -- 2F |

MAGNALOY'S VERTICAL WELDED STEEL MOUNTS utilize an Oversize Motor Flange-Tank Top Mounting design. Tank top openings (TP) and mounting hole dimensions (XT & T) are shown on the following drawing and tables. These mounts are also available for metric size motors and pumps, consult factory for special requirements. To select a welded steel vertical mount follow the selection method detailed on page 8. The length determined will be the minimum length recommended, additional length can be added depending upon coupling selection, consult factory for further assistance.

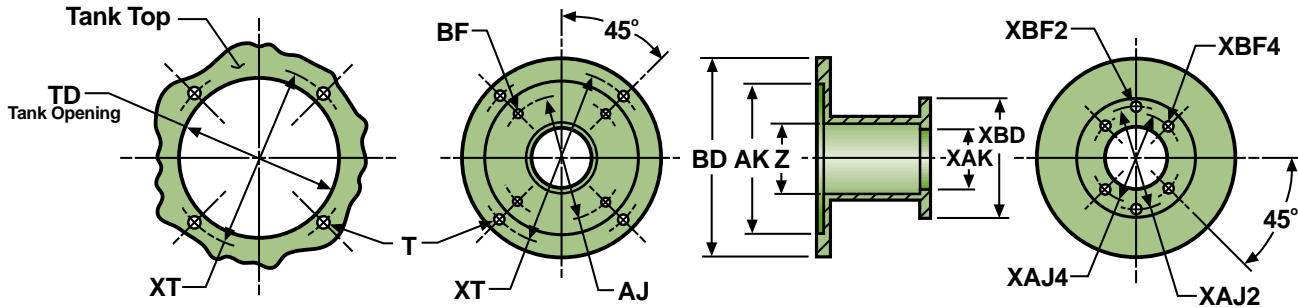

TABLE 24 - NEMA 56C, 143TC/145TC, 182UC/184UC

| MOTOR END DATA | | | PUMP END DATA | | | | | | | MOTOR END DATA | | | MOUNT NO. | (METRIC SIZES ALSO AVAILABLE) |
|----------------|-----------|-------|---------------|------|--------|------|---------|------|-------|----------------|-------|--------------|-----------|-------------------------------|
| AJ | BF | AK | XAK | XAJ2 | XBF2 | XAJ4 | XBF4 | XBD | BD | XT | TD | | | |
| 5.88 | 7/16 | 4.501 | 1.782 | | | 2.84 | 5/16-18 | 5.25 | 11.38 | 10.25 | 9.125 | S056 -- 4FV | | |
| SAE AA | 2 Bolt | | 2.001 | 3.25 | 3/8-16 | | | 5.25 | 11.38 | 10.25 | 9.125 | S056 -- 2AAV | | |
| SAE A | 2(4) Bolt | | 3.251 | 4.19 | 3/8-16 | 4.12 | 3/8-16 | 5.25 | 11.38 | 10.25 | 9.125 | S056 -- 2AV | | |
| SAE B | 2(4) Bolt | | 4.001 | 5.75 | 1/2-13 | 5.00 | 1/2-13 | 7.00 | 11.38 | 10.25 | 9.125 | S056 -- 2BV | | |
| SAE C | 2(4) Bolt | | 5.001 | 7.12 | 5/8-11 | 6.38 | 1/2-13 | 8.25 | 11.38 | 10.25 | 9.125 | S056 -- 2CV | | |

TABLE 25 - NEMA 182TC - 256TC, 254UC/256UC

| MOTOR END DATA | | | PUMP END DATA | | | | | | | MOTOR END DATA | | | MOUNT NO. | (METRIC SIZES ALSO AVAILABLE) |
|----------------|-----------|-------|---------------|------|--------|------|---------|-------|-------|----------------|-------|--------------|-----------|-------------------------------|
| AJ | BF | AK | XAK | XAJ2 | XBF2 | XAJ4 | XBF4 | XBD | BD | XT | TD | | | |
| 7.25 | 17/32 | 8.501 | 1.782 | | | 2.84 | 5/16-18 | 6.00 | 11.50 | 10.25 | 9.125 | S182 -- 4FV | | |
| SAE AA | 2 Bolt | | 2.001 | 3.25 | 3/8-16 | | | 6.00 | 11.50 | 10.25 | 9.125 | S182 -- 2AAV | | |
| SAE A | 2(4) Bolt | | 3.251 | 4.19 | 3/8-16 | 4.12 | 3/8-16 | 6.00 | 11.50 | 10.25 | 9.125 | S182 -- 2AV | | |
| SAE B | 2(4) Bolt | | 4.001 | 5.75 | 1/2-13 | 5.00 | 1/2-13 | 7.00 | 11.50 | 10.25 | 9.125 | S182 -- 2BV | | |
| SAE C | 2(4) Bolt | | 5.001 | 7.12 | 5/8-11 | 6.38 | 1/2-13 | 8.25 | 11.50 | 10.25 | 9.125 | S182 -- 2CV | | |
| SAE D | 2(4) Bolt | | 6.001 | 9.00 | 3/4-10 | 9.00 | 3/4-10 | 10.50 | 12.62 | 11.50 | 11.00 | S182 -- 2DV | | |

TABLE 26 - NEMA 284TC/TSC - 286TC/TSC, 284UC/286UC

MOTOR END DATA
AJ BF AK
9.00 17/32 10.501

RADIAL CLEARANCE "Z" = 6.06
MOUNTING HOLE DIA "T" = 17/32

| | | XAK | XAJ2 | XBF2 | XAJ4 | XBF4 | XBD | BD | XT | TD | MOUNT NO. |
|--------------|-----------|-------|-------|--------|-------|--------|-------|-------|-------|-------|--------------------|
| SAE A | 2(4) Bolt | 3.251 | 4.19 | 3/8-16 | 4.12 | 3/8-16 | 7.00 | 13.50 | 12.25 | 10.75 | S284 -- 2AV |
| SAE B | 2(4) Bolt | 4.001 | 5.75 | 1/2-13 | 5.00 | 1/2-13 | 7.00 | 13.50 | 12.25 | 10.75 | S284 -- 2BV |
| SAE C | 2(4) Bolt | 5.001 | 7.12 | 5/8-11 | 6.38 | 1/2-13 | 8.25 | 13.50 | 12.25 | 10.75 | S284 -- 2CV |
| SAE D | 2(4) Bolt | 6.001 | 9.00 | 3/4-10 | 9.00 | 3/4-10 | 10.50 | 13.50 | 12.25 | 10.75 | S284 -- 2DV |
| SAE E | 2(4) Bolt | 6.501 | 12.50 | 1-8 | 12.50 | 3/4-10 | 15.00 | 18.00 | 16.50 | 15.25 | S284 -- 2EV |
| SAE F | 2(4) Bolt | 7.001 | 13.78 | 1-8 | 13.78 | 1-8 | 16.00 | 19.50 | 18.00 | 16.50 | S284 -- 2FV |

PUMP FLANGE PUMP END DATA MOTOR END DATA

(METRIC SIZES ALSO AVAILABLE)

TABLE 27 - NEMA 324TC/TSC - 405TC/TSC, 324UC/USC - 405UC/USC

MOTOR END DATA
AJ BF AK
11.00 21/32 12.501

RADIAL CLEARANCE "Z" (See Below)
MOUNTING HOLE DIA "T" = 21/32

| | | XAK | XAJ2 | XBF2 | XAJ4 | XBF4 | XBD | Z | BD | XT | TD | MOUNT NO. |
|--------------|-----------|-------|-------|--------|-------|--------|-------|------|-------|-------|-------|--------------------|
| SAE A | 2(4) Bolt | 3.251 | 4.19 | 3/8-16 | 4.12 | 3/8-16 | 9.25 | 7.98 | 18.00 | 16.50 | 15.25 | S324 -- 2AV |
| SAE B | 2(4) Bolt | 4.001 | 5.75 | 1/2-13 | 5.00 | 1/2-13 | 9.25 | 7.98 | 18.00 | 16.50 | 15.25 | S324 -- 2BV |
| SAE C | 2(4) Bolt | 5.001 | 7.12 | 5/8-11 | 6.38 | 1/2-13 | 9.25 | 7.98 | 18.00 | 16.50 | 15.25 | S324 -- 2CV |
| SAE D | 2(4) Bolt | 6.001 | 9.00 | 3/4-10 | 9.00 | 3/4-10 | 10.50 | 7.98 | 18.00 | 16.50 | 15.25 | S324 -- 2DV |
| SAE E | 2(4) Bolt | 6.501 | 12.50 | 1-8 | 12.50 | 3/4-10 | 15.00 | 7.98 | 18.00 | 16.50 | 15.25 | S324 -- 2EV |
| SAE F | 2(4) Bolt | 7.001 | 13.78 | 1-8 | 13.78 | 1-8 | 16.00 | 9.00 | 19.50 | 18.00 | 16.50 | S324 -- 2FV |

PUMP FLANGE PUMP END DATA MOTOR END DATA

(METRIC SIZES ALSO AVAILABLE)

TABLE 28 - NEMA 444TC/TSC - 449TC/TSC, 444UC/USC - 445UC/USC

MOTOR END DATA
AJ BF AK
14.00 21/32 16.001

RADIAL CLEARANCE "Z" = 10.02
MOUNTING HOLE DIA "T" = 21/32

| | | XAK | XAJ2 | XBF2 | XAJ4 | XBF4 | XBD | BD | XT | TD | MOUNT NO. |
|--------------|-----------|-------|-------|--------|-------|--------|-------|-------|-------|-------|--------------------|
| SAE A | 2(4) Bolt | 3.251 | 4.19 | 3/8-16 | 4.12 | 3/8-16 | 11.25 | 19.50 | 18.00 | 16.50 | S444 -- 2AV |
| SAE B | 2(4) Bolt | 4.001 | 5.75 | 1/2-13 | 5.00 | 1/2-13 | 11.25 | 19.50 | 18.00 | 16.50 | S444 -- 2BV |
| SAE C | 2(4) Bolt | 5.001 | 7.12 | 5/8-11 | 6.38 | 1/2-13 | 11.25 | 19.50 | 18.00 | 16.50 | S444 -- 2CV |
| SAE D | 2(4) Bolt | 6.001 | 9.00 | 3/4-10 | 9.00 | 3/4-10 | 11.25 | 19.50 | 18.00 | 16.50 | S444 -- 2DV |
| SAE E | 2(4) Bolt | 6.501 | 12.50 | 1-8 | 12.50 | 3/4-10 | 15.00 | 19.50 | 18.00 | 16.50 | S444 -- 2EV |
| SAE F | 2(4) Bolt | 7.001 | 13.78 | 1-8 | 13.78 | 1-8 | 16.00 | 19.50 | 18.00 | 16.50 | S444 -- 2FV |

PUMP FLANGE PUMP END DATA MOTOR END DATA

(METRIC SIZES ALSO AVAILABLE)

MAGNALOY'S WELDED STEEL ENGINE MOUNTS are available for all engine pilot size configurations in addition to the 4 basic sizes listed. Metric pump flanges are also available, consult factory for special requirements. To select a welded steel pump/engine mount follow the selection method detailed on page 11. The length determined will be the minimum length recommended, additional length can be added depending upon coupling selection, consult factory for further assistance.

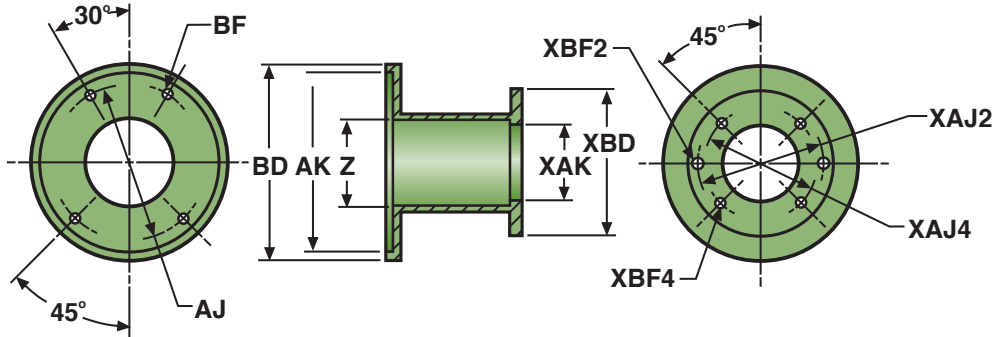

TABLE 29 - E575 Pilot Gasoline and Diesel Engines

RADIAL CLEARANCE "Z" = 4.03

| ENGINE END DATA | | | | | | | | | | |
|-----------------|-----------|------|-------|-------|------|----------|------|-----------|------|--------------|
| AJ | BF | BD | AK | XAK | XAJ2 | XBF2 | XAJ4 | XBF4 | XBD | MOUNT NO. |
| 6.50 | 13/32 | 7.50 | 3.752 | | | | | | | |
| USA4F17 | 4 Bolt | | | 1.782 | | | 2.84 | 5/16 - 18 | 5.25 | SE575 -- 4F |
| SAE AA | 2 Bolt | | | 2.001 | 3.25 | 3/8 - 16 | | | 5.25 | SE575 -- 2AA |
| SAE A | 2(4) Bolt | | | 3.251 | 4.19 | 3/8 - 16 | 4.12 | 3/8 - 16 | 5.25 | SE575 -- 2A |
| SAE B | 2(4) Bolt | | | 4.001 | 5.75 | 1/2 - 13 | 5.00 | 1/2 - 13 | 7.00 | SE575 -- 2B |

(METRIC SIZES ALSO AVAILABLE)

TABLE 30 - E644 Pilot Gasoline and Diesel

RADIAL CLEARANCE "Z" = 5.04

| ENGINE END DATA | | | | | | | | | | |
|-----------------|-----------|------|-------|-------|------|----------|------|-----------|-------|--------------|
| AJ | BF | BD | AK | XAK | XAJ2 | XBF2 | XAJ4 | XBF4 | XBD | MOUNT NO. |
| 7.75 | 15/32 | 9.00 | 6.440 | | | | | | | |
| USA4F17 | 4 Bolt | | | 1.782 | | | 2.84 | 5/16 - 18 | 5.25 | SE644 -- 4F |
| SAE AA | 2 Bolt | | | 2.001 | 3.25 | 3/8 - 16 | | | 5.25 | SE644 -- 2AA |
| SAE A | 2(4) Bolt | | | 3.251 | 4.19 | 3/8 - 16 | 4.12 | 3/8 - 16 | 5.25 | SE644 -- 2A |
| SAE B | 2(4) Bolt | | | 4.001 | 5.75 | 1/2 - 13 | 5.00 | 1/2 - 13 | 7.00 | SE644 -- 2B |
| SAE C | 2(4) Bolt | | | 5.001 | 7.12 | 5/8 - 11 | 6.38 | 1/2 - 13 | 8.25 | SE644 -- 2C |
| SAE D | 2(4) Bolt | | | 6.001 | 9.00 | 3/4 - 10 | 9.00 | 3/4 - 10 | 10.50 | SE644 -- 2D |

(METRIC SIZES ALSO AVAILABLE)

TABLE 31 - E700 Pilot Gasoline and Diesel Engines

ENGINE END DATA **RADIAL CLEARANCE "Z" = 5.04**

| | | AJ | BF | BD | AK | | | | | | MOUNT NO. | |
|----------------|-----------|------|-------|------|-------|-------|------|----------|------|-----------|-----------|---------------------|
| | | 7.75 | 15/32 | 9.00 | 7.002 | XAK | XAJ2 | XBF2 | XAJ4 | XBF4 | XBD | |
| USA4F17 | 4 Bolt | | | | | 1.782 | | | 2.84 | 5/16 - 18 | 5.25 | SE700 -- 4F |
| SAE AA | 2 Bolt | | | | | 2.001 | 3.25 | 3/8 - 16 | | | 5.25 | SE700 -- 2AA |
| SAE A | 2(4) Bolt | | | | | 3.251 | 4.19 | 3/8 - 16 | 4.12 | 3/8 - 16 | 5.25 | SE700 -- 2A |
| SAE B | 2(4) Bolt | | | | | 4.001 | 5.75 | 1/2 - 13 | 5.00 | 1/2 - 13 | 7.00 | SE700 -- 2B |
| SAE C | 2(4) Bolt | | | | | 5.001 | 7.12 | 5/8 - 11 | 6.38 | 1/2 - 13 | 8.25 | SE700 -- 2C |
| SAE D | 2(4) Bolt | | | | | 6.001 | 9.00 | 3/4 - 10 | 9.00 | 3/4 - 10 | 10.50 | SE700 -- 2D |

PUMP FLANGE **PUMP END DATA**

(METRIC SIZES ALSO AVAILABLE)

TABLE 32 - E787 Pilot Gasoline and Diesel Engines

ENGINE END DATA **RADIAL CLEARANCE "Z" = 6.06**

| | | AJ | BF | BD | AK | | | | | | MOUNT NO. | |
|----------------|-----------|------|-------|-------|-------|-------|------|----------|------|-----------|-----------|---------------------|
| | | 9.25 | 21/32 | 11.00 | 7.871 | XAK | XAJ2 | XBF2 | XAJ4 | XBF4 | XBD | |
| USA4F17 | 4 Bolt | | | | | 1.782 | | | 2.84 | 5/16 - 18 | 5.25 | SE787 -- 4F |
| SAE AA | 2 Bolt | | | | | 2.001 | 3.25 | 3/8 - 16 | | | 5.25 | SE787 -- 2AA |
| SAE A | 2(4) Bolt | | | | | 3.251 | 4.19 | 3/8 - 16 | 4.12 | 3/8 - 16 | 5.25 | SE787 -- 2A |
| SAE B | 2(4) Bolt | | | | | 4.001 | 5.75 | 1/2 - 13 | 5.00 | 1/2 - 13 | 7.00 | SE787 -- 2B |
| SAE C | 2(4) Bolt | | | | | 5.001 | 7.12 | 5/8 - 11 | 6.38 | 1/2 - 13 | 8.25 | SE787 -- 2C |
| SAE D | 2(4) Bolt | | | | | 6.001 | 9.00 | 3/4 - 10 | 9.00 | 3/4 - 10 | 10.50 | SE787 -- 2D |

PUMP FLANGE **PUMP END DATA**

(METRIC SIZES ALSO AVAILABLE)

Make the Connection with **magnaloy**.....

*Whatever your Fluid Power Unit needs,
magnaloy has the products
to keep you connected.*



Flexible Drive Couplings

Top-of-the-line magnesium couplings are lighter, yet stronger than either cast iron or aluminum. They also offer better corrosion resistance and easier handling.



Magnaloy Hydraulic Bar Manifolds & Accessories

Complete line of inline Bar Manifolds, Subplates, Cover Plates, Valve Adaptors, Integrated Circuit Manifolds, and Accessories to make the design and fabrication of Hydraulic Circuitry simple and easy. Wide range of sizes include: D03, D05, D05H & D08 in aluminum and steel with ports available in SAE, NPTF, BSPP, and BSTP styles. Custom design and fabrication also available, consult factory.

Accessories

Filler Breather Adaptors, Filler Breathers, Reservoir Flanges, Suction Strainers, Gauge Isolators, Liquid Level Gauges, Modular O-Ring Kits.

Pump/Motor Mounts

Precision machined aluminum & custom steel pump/motor mounts directly connect the motor and pump while ensuring accurate shaft alignment and enclosing the coupling. Vertical and horizontal models readily available from stock.



Rod End Couplers

Two models of accurately machined high tensile cylinder rod end alignment couplers offer 7° or 10° spherical and 1/8" parallel misalignment capabilities.



PM 90 Couplings

Economical PM-90 Iron Powder Couplings have long lasting nitrile, hytel or urethane inserts. Double set screws give excellent gripping power.



Magnaloy Reservoirs & Reservoir Accessories

Magnaloy offers a complete line of standard reservoirs and reservoir accessories. In addition, we offer custom reservoir fabrication to meet our customer specific needs. Reservoirs accessories such as Clean Out Covers and SAE Couplings are available for the "do-it-yourself" reservoir manufacturer.



Magnaloy Pressure Switch

Pressure Sensing switch capable of sensing up to three (3) separate pressures. Each sensor is externally independently adjustable from 200 to 4000 psi. Viton seals provide wide fluid compatibility range.